

**JOHN DEERE**  
**WORLDWIDE CONSTRUCTION AND**  
**FORESTRY DIVISION**

---

**Skid Steer**  
**280**

TM1749 MAR04

**TECHNICAL MANUAL**



**JOHN DEERE**

**280**  
**Skid Steer**

**TM1749 (MAR04)**



**Thanks very much for your reading,  
Want to get more information,  
Please click here, Then get the complete  
manual**

**JustClickHere** 

**NOTE:**

**If there is no response to click on the link above,  
please download the PDF document first, and then  
click on it.**

**Have any questions please write to me:  
[admin@servicemanualperfect.com](mailto:admin@servicemanualperfect.com)**

This technical manual is written for an experienced technician and contains sections that are specifically for this product. It is a part of a total product support program.

The manual is organized so that all the information on a particular system is kept together. The order of grouping is as follows:

- Table of Contents
- Specifications
- Theory of Operation
- Troubleshooting Diagram
- Diagnostics
- Tests & Adjustments
- Repair

*Note: Depending on the particular section or system being covered, not all of the above groups may be used.*

Each section will be identified with a symbol rather than a number. The groups and pages within a section will be consecutively numbered.

All information, illustrations and specifications in this manual are based on the latest information available at the time of publication. The right is reserved to make changes at any time without notice.

We appreciate your input on this manual. To help, there are postage paid post cards included at the back. If you find any errors or want to comment on the layout of the manual please fill out one of the cards and mail it back to us.

**Safety**



**Specifications and Information**



**Engine (Diesel)**



**Electrical**



**Power Train  
(Chain Case and Axles)**



**Power Train  
(Hydrostatic)**



**Steering**



**Brakes**



**Hydraulics**



**Miscellaneous**



COPYRIGHT© 2003

JOHN DEERE

CONSTRUCTION AND FORESTRY DIVISION

Dubuque, Iowa

All rights reserved

Previous Editions

Copyright© 1999, 2000—2002 Deere & Company



**SAFETY**

**RECOGNIZE SAFETY INFORMATION**

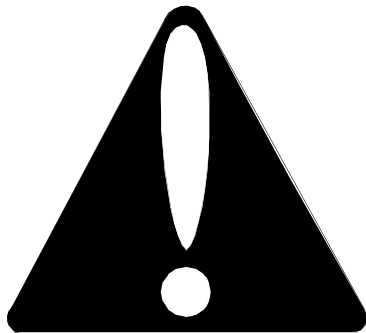

This is the safety-alert symbol. When you see this symbol on your machine or in this manual, be alert to the potential for personal injury.

Follow recommended precautions and safe servicing practices.

**Understand Signal Words**

A signal word—**DANGER**, **WARNING**, or **CAUTION**—is used with the safety-alert symbol. **DANGER** identifies the most serious hazards.

**DANGER** or **WARNING** safety signs are located near specific hazards. General precautions are listed on **CAUTION** safety signs. **CAUTION** also calls attention to safety messages in this manual.

**REPLACE SAFETY SIGNS**



Replace missing or damaged safety signs. See the machine operator's manual for correct safety sign placement.

**HANDLE FLUIDS SAFELY—AVOID FIRES**

**Be Prepared For Emergencies**

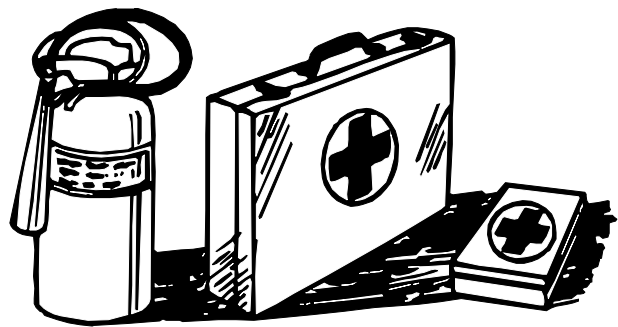
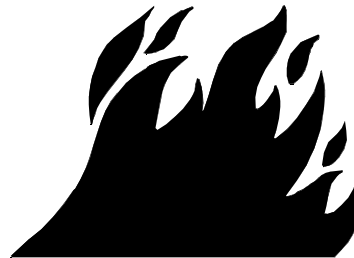

When you work around fuel, do not smoke or work near heaters or other fire hazards.

Store flammable fluids away from fire hazards. Do not incinerate or puncture pressurized containers.

Make sure machine is clean of trash, grease, and debris.

Do not store oily rags; they can ignite and burn spontaneously.

Be prepared if a fire starts.

Keep a first aid kit and fire extinguisher handy.

Keep emergency numbers for doctors, ambulance service, hospital, and fire department near your telephone.

## USE CARE IN HANDLING AND SERVICING BATTERIES

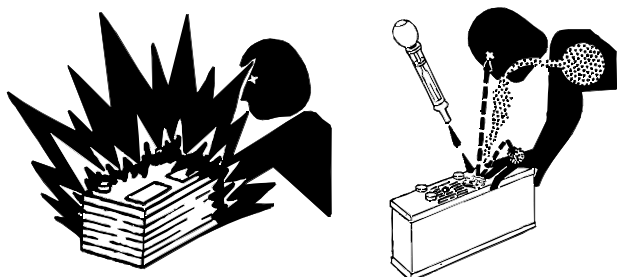

### Prevent Battery Explosions

- Keep sparks, lighted matches, and open flame away from the top of battery. Battery gas can explode.
- Never check battery charge by placing a metal object across the posts. Use a volt-meter or hydrometer.
- Do not charge a frozen battery; it may explode. Warm battery to 16°C (60°F).

### Prevent Acid Burns

- Sulfuric acid in battery electrolyte is poisonous. It is strong enough to burn skin, eat holes in clothing, and cause blindness if splashed into eyes.
- **Avoid acid burns by:**
  1. Filling batteries in a well-ventilated area.
  2. Wearing eye protection and rubber gloves.
  3. Avoiding breathing fumes when electrolyte is added.
  4. Avoiding spilling or dripping electrolyte.
  5. Using proper jump start procedure.
- **If you spill acid on yourself:**
  1. Flush your skin with water.
  2. Apply baking soda or lime to help neutralize the acid.
  3. Flush your eyes with water for 10—15 minutes.
  4. Get medical attention immediately.
- **If acid is swallowed:**
  1. Drink large amounts of water or milk.
  2. Then drink milk of magnesia, beaten eggs, or vegetable oil.
  3. Get medical attention immediately.

## USE CARE AROUND HIGH-PRESSURE FLUID LINES

### Avoid High-Pressure Fluids

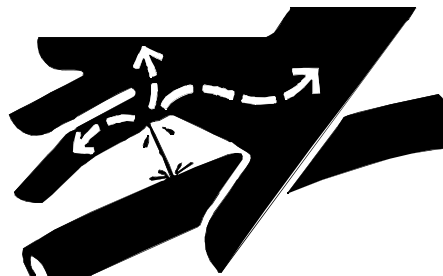

Escaping fluid under pressure can penetrate the skin causing serious injury.

Avoid injury from escaping fluid under pressure by stopping the engine and relieving pressure in the system before disconnecting or connecting hydraulic or other lines. Tighten all connections before applying pressure.

Search for leaks with a piece of cardboard. Protect hands and body from high pressure fluids.

If an accident occurs, see a doctor immediately. Any fluid injected into the skin must be surgically removed within a few hours or gangrene may result. Doctors unfamiliar with this type of injury should reference a knowledgeable medical source. Such information is available from Deere & Company Medical Department in Moline, Illinois, U.S.A., (1-800-822-8262 U.S.A. or Canada).

## SAFETY

---



### Avoid Heating Near Pressurized Fluid Lines



Flammable spray can be generated by heating near pressurized fluid lines, resulting in severe burns to yourself and bystanders. Do not heat by welding, soldering, or using a torch near pressurized fluid lines or other flammable materials. Pressurized lines can be accidentally cut when heat goes beyond the immediate flame area.

## USE SAFE SERVICE PROCEDURES

### Wear Protective Clothing

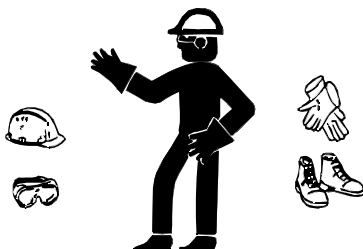

Wear close fitting clothing and safety equipment appropriate to the job.

Prolonged exposure to loud noise can cause impairment or loss of hearing. Wear a suitable hearing protective device such as earmuffs or earplugs to protect against objectionable or uncomfortable loud noises.

Operating equipment safely requires the full attention of the operator. Do not wear radio or music headphones while operating machine.

### Service Machines Safely

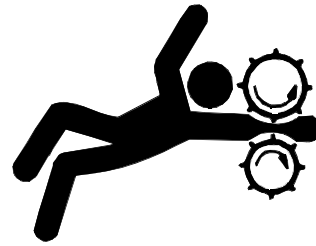

Tie long hair behind your head. Do not wear a necktie, scarf, loose clothing, or necklace when you work near machine tools or moving parts. If these items were to get caught, severe injury could result.

Remove rings and other jewelry to prevent electrical shorts and entanglement in moving parts.

### Use Proper Tools

Use tools appropriate to the work. Makeshift tools and procedures can create safety hazards. Use power tools only to loosen threaded parts and fasteners. For loosening and tightening hardware, use the correct size tools. **DO NOT** use U.S. measurement tools on metric fasteners. Avoid bodily injury caused by slipping wrenches. Use only service parts meeting John Deere specifications.

### Park Machine Safely

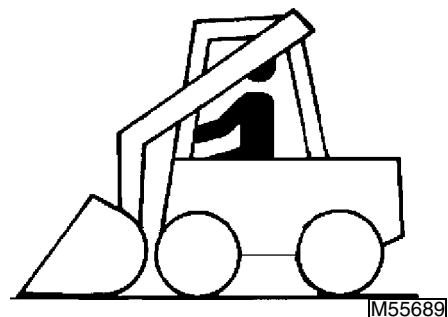

#### Before working on the machine:

1. Lower all equipment to the ground.
2. Relieve hydraulic pressure.
3. Stop the engine and remove the key.
4. Disconnect the battery ground strap.
5. Hang a "DO NOT OPERATE" tag in operator station.

## Support Machine Properly and Use Proper Lifting Equipment

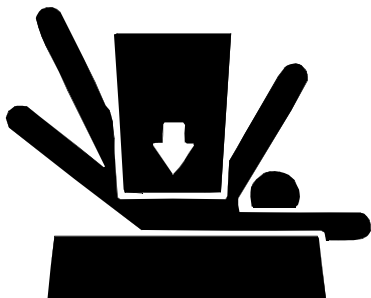

If you must work on a lifted machine or attachment, securely support the machine or attachment.

Do not support the machine on cinder blocks, hollow tiles, or props that may crumble under continuous load. Do not work under a machine that is supported solely by a jack. Follow recommended procedures in this manual.

Lifting heavy components incorrectly can cause severe injury or machine damage. Follow recommended procedure for removal and installation of components in the manual.

## Work In Clean Area

### Before starting a job:

1. Clean work area and machine.
2. Make sure you have all necessary tools to do your job.
3. Have the right parts on hand.
4. Read all instructions thoroughly; do not attempt shortcuts.

## Using High Pressure Washers

Directing pressurized water at electronic/electrical components or connectors, bearings, hydraulic seals, fuel injection pumps or other sensitive parts and components may cause product malfunctions. Reduce pressure and spray component at a 45 to 90 degree angle.

## Illuminate Work Area Safely

Illuminate your work area adequately but safely. Use a portable safety light for working inside or under the machine. Make sure the bulb is enclosed by a wire cage. The hot filament of an accidentally broken bulb can ignite spilled fuel or oil.

## Work In Ventilated Area

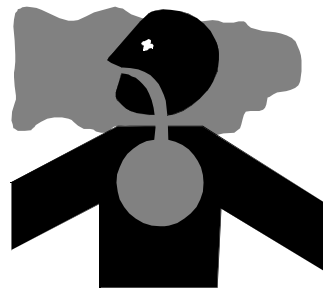

Engine exhaust fumes can cause sickness or death. If it is necessary to run an engine in an enclosed area, remove the exhaust fumes from the area with an exhaust duct system.

If you do not have an exhaust duct system, open the doors and get outside air into the area.

## WARNING: California Proposition 65 Warning

Diesel engine exhaust and some of its constituents are known to the State of California to cause cancer, birth defects, and other reproductive harm.

## Remove Paint Before Welding or Heating

Avoid potentially toxic fumes and dust. Hazardous fumes can be generated when paint is heated by welding, soldering, or using a torch. Do all work outside or in a well-ventilated area. Dispose of paint and solvent properly. Remove paint before welding or heating. If you sand or grind paint, avoid breathing the dust. Wear an approved respirator. If you use solvent or paint stripper, remove stripper with soap and water before welding. Remove solvent or paint stripper containers and other flammable material from area. Allow fumes to disperse at least 15 minutes before welding or heating.





## SAFETY

---



### SERVICE TIRES SAFELY

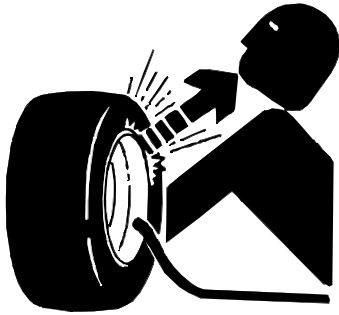

Explosive separation of a tire and rim parts can cause serious injury or death.

Do not attempt to mount a tire unless you have the proper equipment and experience to perform the job. Always maintain the correct tire pressure. Do not inflate the tires above the recommended pressure. Never weld or heat a wheel and tire assembly. The heat can cause an increase in air pressure resulting in a tire explosion. Welding can structurally weaken or deform the wheel.

When inflating tires, use a clip-on chuck and extension hose long enough to allow you to stand to one side and NOT in front of or over the tire assembly. Use a safety cage if available.

Check wheels for low pressure, cuts, bubbles, damaged rims or missing lug bolts and nuts.

### SERVICE COOLING SYSTEM SAFELY



Explosive release of fluids from pressurized cooling system can cause serious burns.

Shut off machine. Only remove filler cap when cool enough to touch with bare hands. Slowly loosen cap to first stop to relieve pressure before removing completely.

---

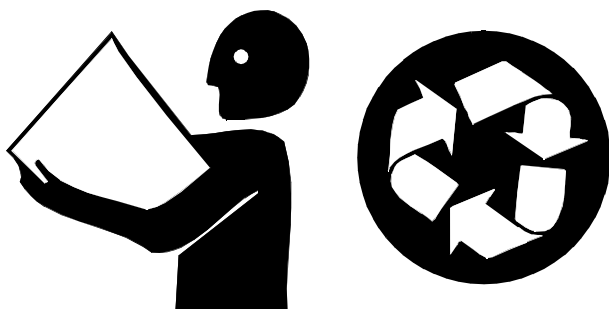
**HANDLE CHEMICAL PRODUCTS SAFELY**

Direct exposure to hazardous chemicals can cause serious injury. Potentially hazardous chemicals used with John Deere equipment include such items as lubricants, coolants, paints, and adhesives.

A Material Safety Data Sheet (MSDS) provides specific details on chemical products: physical and health hazards, safety procedures, and emergency response techniques. Check the MSDS before you start any job using a hazardous chemical. That way you will know exactly what the risks are and how to do the job safely. Then follow procedures and recommended equipment.

**Dispose of Waste Properly**

Improperly disposing of waste can threaten the environment and ecology. Potentially harmful waste used with John Deere equipment include such items as oil, fuel, coolant, brake fluid, filters, and batteries. Use leakproof containers when draining fluids. Do not use food or beverage containers that may mislead someone into drinking from them. Do not pour waste onto the ground, down a drain, or into any water source. Inquire on the proper way to recycle or dispose of waste from your local environmental or recycling center, or from your John Deere dealer.

**LIVE WITH SAFETY**

Before returning machine to customer, make sure machine is functioning properly, especially the safety systems. Install all guards and shields.



# SAFETY

---



This page intentionally left blank.

# CONTENTS

## SPECIFICATIONS AND INFORMATION

	Page
<b>SPECIFICATIONS</b> .....	<b>2</b>
ENGINE.....	2
FUEL SYSTEM.....	2
ELECTRICAL SYSTEM.....	2
CAPACITIES.....	3
HYDRAULICS AND HYDROSTATICS.....	3
DIMENSIONS.....	4
TIRES (STANDARD).....	4
RECOMMENDED LUBRICANTS.....	4
<b>METRIC FASTENER TORQUE VALUES</b> .....	<b>5</b>
<b>METRIC FASTENER TORQUE VALUES—GRADE 7</b> .....	<b>6</b>
<b>INCH FASTENER TORQUE VALUES</b> .....	<b>7</b>
<b>O-RING SEAL SERVICE RECOMMENDATIONS</b> .....	<b>8</b>
FACE SEAL FITTINGS WITH INCH STUD ENDS TORQUE.....	8
FACE SEAL FITTINGS WITH METRIC STUD ENDS TORQUE.....	9
O-RING FACE SEAL FITTINGS.....	10
O-RING BOSS FITTINGS.....	10
<b>DIESEL FUEL SPECIFICATIONS</b> .....	<b>11</b>
LUBRICITY.....	11
STORAGE.....	11
<b>ENGINE OIL SPECIFICATIONS</b> .....	<b>12</b>
4-CYCLE DIESEL ENGINE OIL—NORTH AMERICA.....	12
BREAK-IN DIESEL ENGINE OIL—NORTH AMERICA.....	13
HYDROSTATIC TRANSMISSION AND HYDRAULIC OIL—NORTH AMERICA.....	13
<b>CHAIN CASE OIL SPECIFICATIONS</b> .....	<b>14</b>
CHAIN CASE OIL—NORTH AMERICA.....	14
<b>GENERAL APPLICATION GREASE SPECIFICATIONS</b> .....	<b>15</b>
GREASE—NORTH AMERICA.....	15
<b>COOLANT SPECIFICATIONS</b> .....	<b>15</b>
DIESEL AND GASOLINE ENGINE COOLANT—NORTH AMERICA.....	15
SUPPLEMENTAL COOLANT ADDITIVES.....	16
DIESEL AND GASOLINE ENGINE COOLANT DRAIN INTERVAL—NORTH AMERICA.....	16
<b>SERIAL NUMBER LOCATION</b> .....	<b>17</b>
SKID STEER PRODUCT IDENTIFICATION NUMBER.....	17
ENGINE SERIAL NUMBER.....	17



## SPECIFICATIONS

### ENGINE



Make ..... John Deere  
 Type ..... Diesel  
 Engine Model Number: ..... 4045T  
 Net Horsepower at Rated Engine RPM (2400 RPM) ..... 63.4 kW (85 hp)  
 Cylinders ..... 4  
 Bore ..... 106 mm (4.17 in.)  
 Stroke ..... 127 mm (5.00 in.)  
 Displacement ..... 4.5 L (276 cu in.)  
 Compression Ratio ..... 17.6:1  
 Engine Rated RPM ..... 2400  
 Lubrication ..... Full pressure  
 Oil Filter ..... Full flow (replaceable)  
 Air Cleaner ..... Dry paper with primary and secondary elements  
 Cooling System ..... Liquid-cooled

### FUEL SYSTEM

Fuel ..... Diesel  
 Fuel Filter ..... In-line replaceable filter  
 Fuel Pump ..... Electric  
 Fuel Delivery ..... Rotary injection

### ELECTRICAL SYSTEM

Type ..... 12-volt, electric start  
 Charging System ..... Alternator, 55 amp  
 Battery ..... .950 CCA (cold cranking amps)

**CAPACITIES**

Fuel Tank . . . . .	91 L (24.0 gal)
Hydraulic Reservoir . . . . .	32.2 L (8.5 gal)
Hydraulic System . . . . .	51.1 L (13.5 gal)
Cooling System . . . . .	13.4 L (14 qt)
Engine Oil (with Filter) . . . . .	12.0 L (12.7 qt)
Chain Case (per Side) . . . . .	18.9 L (5 gal)



**HYDRAULICS AND HYDROSTATICS**

Hydrostatic Pumps:	
Type . . . . .	Servo controlled, hydrostatic four wheel drive
Displacement (Max) . . . . .	.45 cm <sup>3</sup> (2.75 in. <sup>3</sup> ) per revolution
Hydrostatic Motor Type	
Single Speed . . . . .	Fixed displacement, radial piston
2-speed . . . . .	Dual displacement, radial piston
Hydraulic/Charge Pump:	
Type . . . . .	High pressure gear pump
Hydraulic Control Valve . . . . .	3-spool open center
Hydraulic Oil Filter . . . . .	Spin-on canister
Charge Oil Filter . . . . .	Spin-on canister
Hydraulic System Flow @ 2400 rpm and 10 340 kPa (1500 psi):	
(Standard) . . . . .	106 L/min (28 gpm) (minimum)
(High-Flow Option) . . . . .	157 L/min (41.5 gpm) (minimum)
Hydrostatic System Relief Pressure . . . . .	37 921 ± 1379 kPa (5500 ± 200 psi)
Charge Circuit Pressure . . . . .	3103 + 689 - 172 kPa (450 +100 - 25 psi)
Hydraulic System Relief Pressure . . . . .	21 374—22 063 kPa (3100—3200 psi)
Boom-Up Circuit Relief Pressure . . . . .	24 338 ± 345 kPa (3530 ± 50 psi)
Boom-Down Circuit Relief Pressure . . . . .	15 341 ± 345 kPa (2225 ± 50 psi)
Bucket-Rollback Circuit Relief Pressure . . . . .	30 337 ± 345 kPa (4400 ± 50 psi)
Bucket-Dump Circuit Relief Pressure . . . . .	24 338 ± 345 kPa (3530 ± 50 psi)
Skid Steer SAE Rated Operating Capacity . . . . .	1451 kg (3200 lb)
Maximum Ground Speed:	
Single Speed and Low Range (2-Speed Models) . . . . .	11.3 km/h (7 mph)
2-Speed . . . . .	19.3 km/h (12.0 mph)
Boom Breakout Force . . . . .	3016 kg (6650 lb)
Bucket Breakout Force . . . . .	5262 kg (11,600 lb)

**DIMENSIONS**

(See note below.)



Overall Operating Height . . . . .	4000 mm (157.5 in.)
Height to ROPS . . . . .	2106 mm (82.9 in.)
Height to Hinge Pin . . . . .	3226 mm (127.0 in.)
Overall Width (less Bucket) . . . . .	1961 mm (77.2 in.)
Overall Width (with Bucket) . . . . .	1981 mm (78.0 in.)
Overall Length (less Bucket) . . . . .	2921 mm (115.0 in.)
Overall Length (with Bucket) . . . . .	3504 mm (138.0 in.)
Wheelbase . . . . .	1235 mm (48.6 in.)
Operating Weight: . . . . .	4173 kg (9200 lb)
Ground Clearance . . . . .	241 mm (9.5 in.)
Dump Height . . . . .	2591 mm (102.0 in.)
Dump Reach . . . . .	813 mm (32.0 in.)
Dump Angle . . . . .	45 degrees
Bucket Rollback . . . . .	35 degrees
Angle of Departure . . . . .	27 degrees

*NOTE: Standard tires (14.00 x 17.50) and 1981 mm (78 in.). Foundry bucket used in determining dimensions.*

**TIRES (STANDARD)**











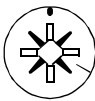

Size . . . . . 14 x 17.5

**RECOMMENDED LUBRICANTS**

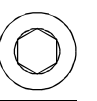
Engine Oil . . . . .	John Deere TORQ-GARD SUPREME® John Deere PLUS-50®
(See ENGINE OIL in the DIESEL ENGINE section for cold weather oil)	
Engine Coolant . . . . .	John Deere COOL-GARD™ John Deere ANTIFREEZE/SUMMER COOLANT
Hydraulic Oil and Hydrostatic Oil . . . . .	John Deere HY-GARD® John Deere Low Viscosity HY-GARD (cold weather operation)
Chain Case Oil . . . . .	John Deere HY-GARD John Deere Low Viscosity HY-GARD (cold weather operation) John Deere TORQ-GARD SUPREME John Deere PLUS-50
Grease . . . . .	John Deere MOLY HIGH TEMPERATURE EP GREASE John Deere NON-CLAY HIGH TEMPERATURE EP GREASE

TORQ-GARD SUPREME, PLUS-50, and HY-GARD are registered trademarks of Deere & Company.  
COOL-GARD is a trademark of Deere & Company.

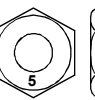
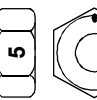
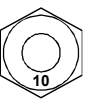
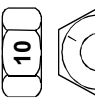
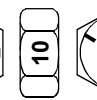
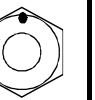
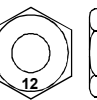
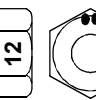
METRIC FASTENER TORQUE VALUES

Property Class and Head Markings	4.8		8.8		9.8		10.9		12.9	
										
Property Class and Nut Markings	5		10		10		10		12	
										

TS1163

SIZE	Class 4.8				Class 8.8 or 9.8				Class 10.9				Class 12.9			
	Lubricated <sup>a</sup>		Dry <sup>a</sup>		Lubricated <sup>a</sup>		Dry <sup>a</sup>		Lubricated <sup>a</sup>		Dry <sup>a</sup>		Lubricated <sup>a</sup>		Dry <sup>a</sup>	
	N•m	lb-ft	N•m	lb-ft	N•m	lb-ft	N•m	lb-ft	N•m	lb-ft	N•m	lb-ft	N•m	lb-ft	N•m	lb-ft
M6	4.8	3.5	6	4.5	9	6.5	11	8.5	13	9.5	17	12	15	11.5	19	14.5
M8	12	8.5	15	11	22	16	28	20	32	24	40	30	37	28	47	35
M10	23	17	29	21	43	32	55	40	63	47	80	60	75	55	95	70
M12	40	29	50	37	75	55	95	70	110	80	140	105	130	95	165	120
M14	63	47	80	60	120	88	150	110	175	130	225	165	205	150	260	109
M16	100	73	125	92	190	140	240	175	275	200	350	225	320	240	400	300
M18	135	100	175	125	260	195	330	250	375	275	475	350	440	325	560	410
M20	190	140	240	180	375	275	475	350	530	400	675	500	625	460	800	580
M22	260	190	330	250	510	375	650	475	725	540	925	675	850	625	1075	800
M24	330	250	425	310	650	475	825	600	925	675	1150	850	1075	800	1350	1000
M27	490	360	625	450	950	700	1200	875	1350	1000	1700	1250	1600	1150	2000	1500
M30	675	490	850	625	1300	950	1650	1200	1850	1350	2300	1700	2150	1600	2700	2000
M33	900	675	1150	850	1750	1300	2200	1650	2500	1850	3150	2350	2900	2150	3700	2750
M36	1150	850	1450	1075	2250	1650	2850	2100	3200	2350	4050	3000	3750	2750	4750	3500

DO NOT use these hand torque values if a different torque value or tightening procedure is given for a specific application. Torque values listed are for general use only and include a ±10% variance factor. Check tightness of fasteners periodically. DO NOT use air powered wrenches.

Shear bolts are designed to fail under predetermined loads. Always replace shear bolts with identical grade.

Fasteners should be replaced with the same class. Make sure fastener threads are clean and that you properly start thread engagement. This will prevent them from failing when tightening.

When bolt and nut combination fasteners are used, torque values should be applied to the **NUT** instead of the bolt head.

Tighten toothed or serrated-type lock nuts to the full torque value.

*a. "Lubricated" means coated with a lubricant such as engine oil, or fasteners with phosphate and oil coatings. "Dry" means plain or zinc plated (yellow dichromate - Specification JDS117) without any lubrication.*

Reference: JDS—G200.













**METRIC FASTENER TORQUE  
VALUES—GRADE 7**



Size	Steel or Gray Iron Torque		Aluminum Torque	
	N•m	lb-ft	N•m	lb-ft
M6	11	8	8	6
M8	24	18	19	14
M10	52	38	41	30
M12	88	65	70	52
M14	138	102	111	82
M16	224	165	179	132

INCH FASTENER TORQUE VALUES



SAE Grade and Head Markings	1 or 2 <sup>b</sup> No Marks 	5  5.1  5.2 	8  8.2 
	2 No Marks 	5  	8  

TS1162

SIZE	Grade 1				Grade 2 <sup>b</sup>				Grade 5, 5.1 or 5.2				Grade 8 or 8.2			
	Lubricated <sup>a</sup>		Dry <sup>a</sup>		Lubricated <sup>a</sup>		Dry <sup>a</sup>		Lubricated <sup>a</sup>		Dry <sup>a</sup>		Lubricated <sup>a</sup>		Dry <sup>a</sup>	
	N•m	lb-ft	N•m	lb-ft	N•m	lb-ft	N•m	lb-ft	N•m	lb-ft	N•m	lb-ft	N•m	lb-ft	N•m	lb-ft
1/4	3.7	2.8	4.7	3.5	6	4.5	7.5	5.5	9.5	7	12	9	13.5	10	17	12.5
5/16	7.7	5.5	10	7	12	9	15	11	20	15	25	18	28	21	35	26
3/8	14	10	17	13	22	16	27	20	35	26	44	33	50	36	63	46
7/16	22	16	28	20	35	26	44	32	55	41	70	52	80	58	100	75
1/2	33	25	42	31	53	39	67	50	85	63	110	80	120	90	150	115
9/16	48	36	60	45	75	56	95	70	125	90	155	115	175	130	225	160
5/8	67	50	85	62	105	78	135	100	170	125	215	160	215	160	300	225
3/4	120	87	150	110	190	140	240	175	300	225	375	280	425	310	550	400
7/8	190	140	240	175	190	140	240	175	490	360	625	450	700	500	875	650
1	290	210	360	270	290	210	360	270	725	540	925	675	1050	750	1300	975
1-1/8	470	300	510	375	470	300	510	375	900	675	1150	850	1450	1075	1850	1350
1-1/4	570	425	725	530	570	425	725	530	1300	950	1650	1200	2050	1500	2600	1950
1-3/8	750	550	950	700	750	550	950	700	1700	1250	2150	1550	2700	2000	3400	2550
1-1/2	1000	725	1250	925	990	725	1250	930	2250	1650	2850	2100	3600	2650	4550	3350

DO NOT use these hand torque values if a different torque value or tightening procedure is given for a specific application. Torque values listed are for general use only and include a ±10% variance factor. Check tightness of fasteners periodically. DO NOT use air powered wrenches.

Shear bolts are designed to fail under predetermined loads. Always replace shear bolts with identical grade.

Fasteners should be replaced with the same grade. Make sure fastener threads are clean and that you properly start thread engagement. This will prevent them from failing when tightening.

When bolt and nut combination fasteners are used, torque values should be applied to the **NUT** instead of the bolt head.

Tighten toothed or serrated-type lock nuts to the full torque value.

a. "Lubricated" means coated with a lubricant such as engine oil, or fasteners with phosphate and oil coatings. "Dry" means plain or zinc plated (yellow dichromate - Specification JDS117) without any lubrication.

b. "Grade 2" applies for hex cap screws (not hex bolts) up to 152 mm (6-in.) long. "Grade 1" applies for hex cap screws over 152 mm (6-in.) long, and for all other types of bolts and screws of any length.

Reference: JDS—G200.

O-RING SEAL SERVICE RECOMMENDATIONS

FACE SEAL FITTINGS WITH INCH STUD ENDS TORQUE

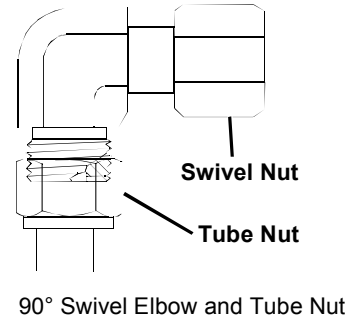
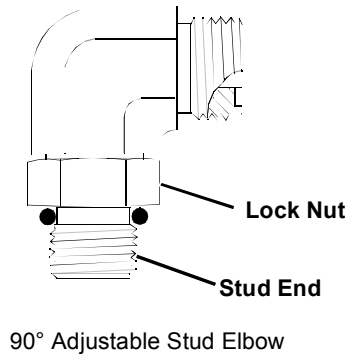
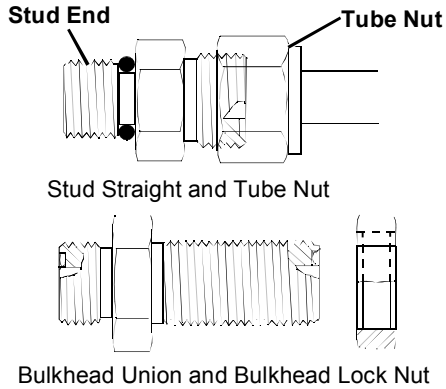

Nominal Tube OD/Hose ID				Face Seal Tube/Hose End					O-Ring Stud Ends		
Metric Tube OD	Inch Tube OD			Thread Size	Tube Nut/ Swivel Nut Torque		Bulkhead Lock Nut Torque		Thread Size	Straight Fitting or Lock Nut Torque	
	mm	Dash Size	in.		mm	in.	N•m	lb-ft		N•m	lb-ft
	-3	0.188	4.76						3/8-24	8	6
6	-4	0.250	6.35	9/16-18	16	12	12	9	7/16-20	12	9
8	-5	0.312	7.94						1/2-20	16	12
10	-6	0.375	9.52	11/16-16	24	18	24	18	9/16-18	24	18
12	-8	0.500	12.70	13/16-16	50	37	46	34	3/4-16	46	34
16	-10	0.625	15.88	1-14	69	51	62	46	7/8-14	62	46
	-12	0.750	19.05	1-3/16-12	102	75	102	75	1-1/16-12	102	75
22	-14	0.875	22.22	1-3/16-12	102	75	102	75	1-3/16-12	122	90
25	-16	1.000	25.40	1-7/16-12	142	105	142	105	1-5/16-12	142	105
32	-20	1.25	31.75	1-11/16-12	190	140	190	140	1-5/8-12	190	140
38	-24	1.50	38.10	2-12	217	160	217	160	1-7/8-12	217	160

NOTE: Torque tolerance is plus 15 minus 20%.